

4000 HN series

Single Output DC/DC Converter



DESCRIPTIONS

The 4000HN, single output power modules are 25 to 40 watt DC/DC converters available in a single output configuration providing 3.3 VDC to 15 VDC outputs in a compact, industry standard 2" X 2" X 0.5" package. These 400kHz, switching converters are available in 12, 24 and 48 VDC inputs making them one of the most versatile product lines in the market with efficiencies up to 89%. Advanced surface mount construction allows these converters to achieve outstanding thermal performance eliminating the need for thermal potting compounds and thereby enhancing manufacturing efficiency to reduce costs.

OUTPUT CHARACTERISTICS

	Min	Typ	Max	Unit/Comments
Output Voltage Set Point		±1		% Output voltage at nominal line & FL
Total Band Error	-2		+2	% Output voltage including line/load regulation setting
Line Regulation		±0.5		% Output voltage measured from min. input line to maximum
Load Regulation		±0.5		% Output voltage measured from FL to 10% load
Temperature Coefficient		±0.01		% per degree C
Ripple/Noise		60	100	mV p-p measured at 20 MHz bandwidth with external 1 uf capacitor
Load Voltage and Current				Refer to model selection chart
Load Transient Response		±2		% Deviation of Vout voltage for a 25% load change for 200µS
Short Circuit Protection				Indefinite, Automatic Recovery
Output Voltage Trim Range		±10		% Output voltage. Place ext. resistor between pins 9 - 6 to trim down. Between pins 9 - 5 to trim up
Overvoltage Protection		120		%; Clamp type

FEATURES

- Up to 89% Efficiency
- Single Output, Up to 40 watt converter
- Available in 12, 24 and 48 VDC Inputs
- Industry Standard 2" X 2" X 0.5" Package
- Output Over Voltage, Input Over Voltage & Short Circuit Protection

INPUT CHARACTERISTICS

	Min	Typ	Max	Units/Comments
Input Voltage				
12 VDC Input Models	9	12	18	VDC
24 VDC Input Models	18	24	36	VDC
48 VDC Input Models	36	48	75	VDC
Under Voltage Shut Down				
12 VDC Input Models		8		VDC
24 VDC Input Models		16		VDC
48 VDC Input Models		33		VDC
Over Voltage Shutdown				
12 VDC Input Models			20	VDC
24 VDC Input Models			40	VDC
48 VDC Input Models			80	VDC
Minimum Input Current				
12 VDC Input Models		0		mA
24 VDC Input Models		0		mA
48 VDC Input Models		0		mA
Full Load Input Current				
12 VDC Input Models			3.13	A
24 VDC Input Models			2.04	A
48 VDC Input Models			1.01	A
Input Fuse Requirements				
12 VDC Input Models			8	Amps; Slow blow type
24 VDC Input Models			5	Amps; Slow blow type
48 VDC Input Models			3	Amps; Slow blow type
Efficiency by Model				
4003S12HN		76		%; FL Nominal Line
4005S12HN		81		%; FL Nominal Line
4012S12HN		85		%; FL Nominal Line
4015S12HN		86		%; FL Nominal Line
4003S24HN		78		%; FL Nominal Line
4005S24HN		83		%; FL Nominal Line
4012S24HN		87		%; FL Nominal Line
4015S24HN		88		%; FL Nominal Line
4003S48HN		80		%; FL Nominal Line
4005S48HN		84		%; FL Nominal Line
4012S48HN		88		%; FL Nominal Line
4015S48HN		89		%; FL Nominal Line
Switching Frequency	360	400	440	kHz; Factory set
Remote Shut Down	Off	0	0.80	VDC; Referenced to input
	On	3.5		VDC or open; Referenced to input
Input - Output Capacitance		1000		pF
Input Filter				LC type
Isolation Voltage		1500		VDC
Isolation Resistance		100		MOhms

MODEL SELECTION CHART

	Input Voltage (VDC)	Output Voltage (VDC)	Full Load Output Current (A)
4003S12HN	12	3	8
4005S12HN	12	5	6
4012S12HN	12	12	2.5
4015S12HN	12	15	2
4003S24HN	24	3	9
4005S24HN	24	5	8
4012S24HN	24	12	3.33
4015S24HN	24	15	2.67
4003S48HN	48	3	10
4005S48HN	48	5	8
4012S48HN	48	12	3.33
4015S48HN	48	15	2.67

GENERAL CHARACTERISTICS

	Min	Typ	Max	Unit/Comments
Operating Temp. Range	-40		+105	°C; measured at baseplate
Storage Temp. Range	-55		+125	°C; measured at baseplate
Material Flammability				UL94V-0
Altitude: Operating			10,000	Feet
Non-Operating			40,000	Feet
Relative Humidity	5		95	% Humidity, non-condensing
MTBF	700,000			Per MIL-HDBK-217F, Ground Benign envir.
Weight			30	Grams
Size				2" X 2" X 0.5"
Case Material				Black coated aluminum
Agency Approvals				UL/CUL1950, TUV, EN60950

OUTLINE DRAWING

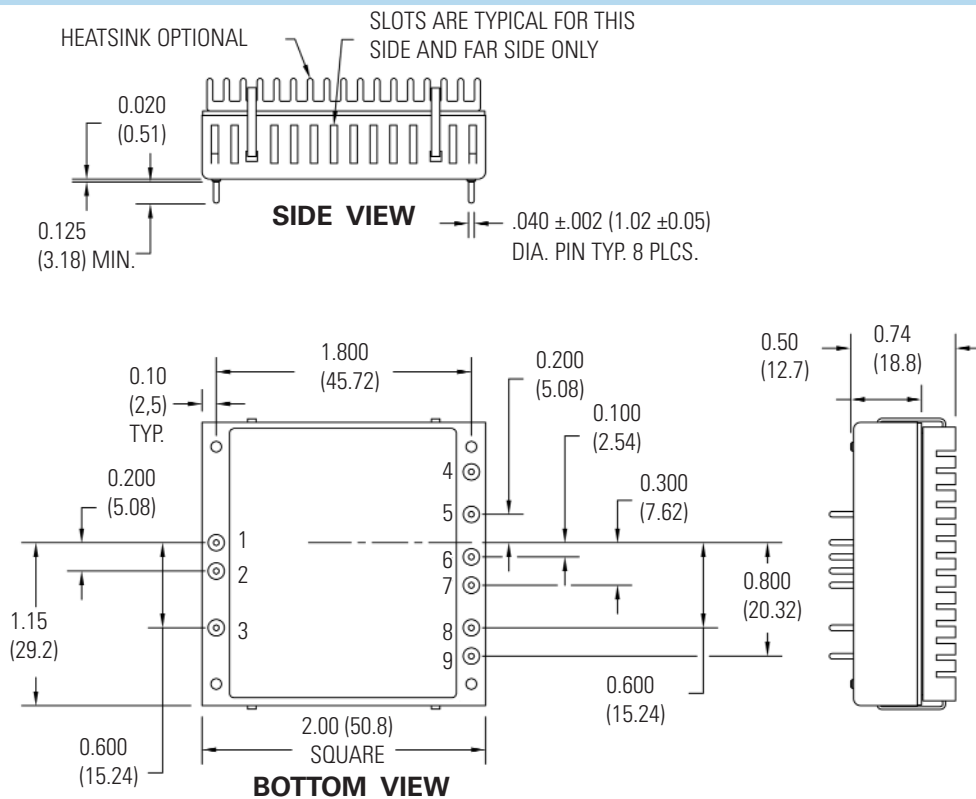

PIN OUT CHART

Pins	FUNCTION
1	+ Vin
2	- Vin
3	CONTROL
4	NO PIN
5	- SENSE
6	+ SENSE
7	+ V OUTPUT
8	- V OUTPUT
9	TRIM

Notes:

- Unless otherwise specified dimensions are in inches (mm).
- Controlling dimension in inch.
- Tolerances

Inches	mm
X.XX = ±0.02	X.X = ±0.5
X.XXX = ±0.010	X.XX = ±0.25

All specifications are typical at nominal input, nominal load and 25° C unless otherwise specified. External, low ESR, 33 microfarad (minimum) capacitor across output is recommended for operation.

HOW TO ORDER

HOW TO ORDER

40 XX S XX HN - Y

Wattage ——— 40

Output Voltage ——— XX

Single Output ——— S

ROHS Compliant ——— Y

Hi-Density, Non-Encap ——— XX

Input Voltage ——— HN

H Options: To add external heatsink mounted on the baseplate of the converter please add a "- H" at the end of the part number. Heatsink is provided to improve thermal performance (see derating curves).

DERATING CURVES

MODEL 4000HN Single 3.3V (Without heatsink)

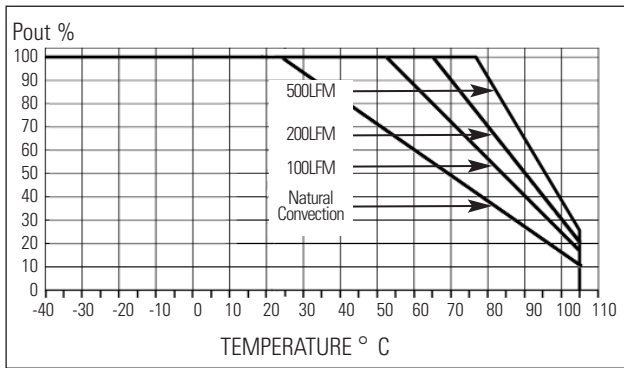

MODEL 4000HN-H Single 3.3V (With heatsink)

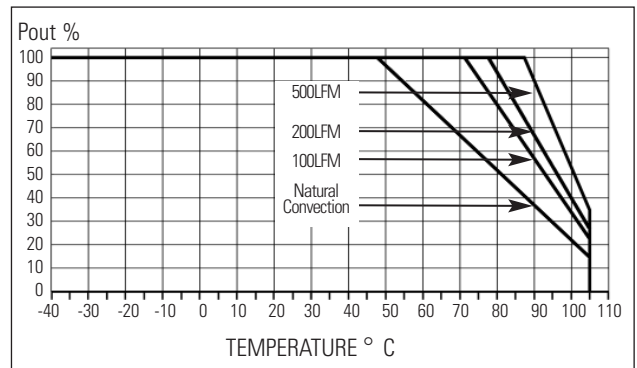

MODEL 4000HN Single 5V (Without heatsink)

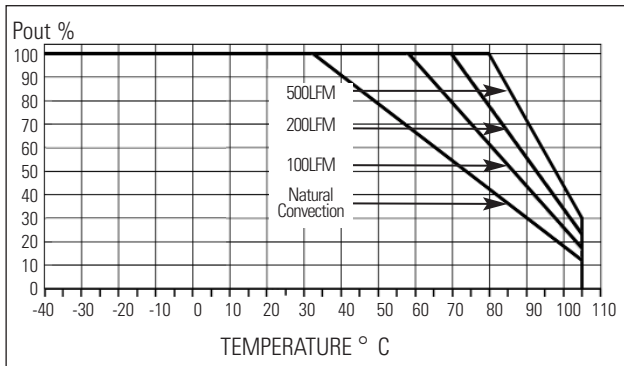

MODEL 4000HN-H Single 5V (With heatsink)

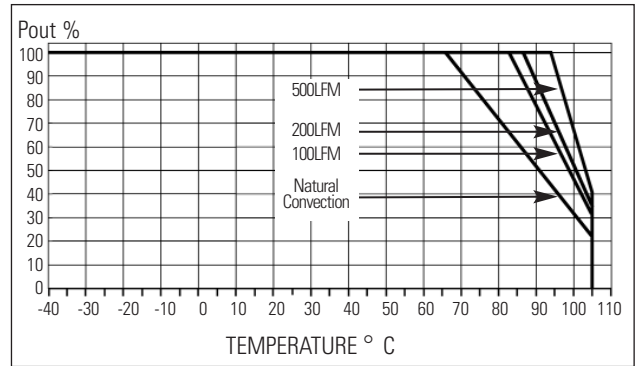

MODEL 4000HN Single 12 & 15V (Without heatsink)

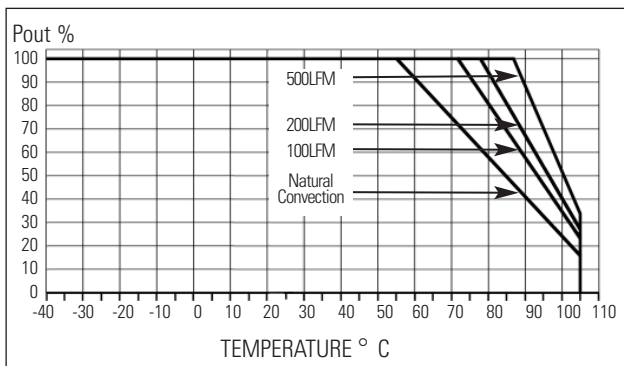

MODEL 4000HN-H Single 12 & 15V (With heatsink)

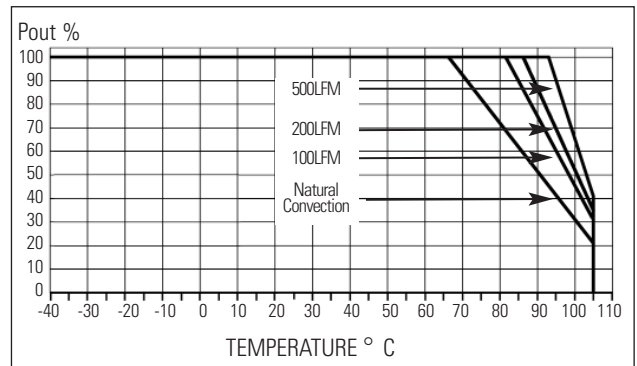

OUTPUT VOLTAGE ADJUSTMENT (4000HN SINGLE SERIES)

The converter's output voltage may be trimmed by up to $\pm 10\%$ of the nominal output voltage.

TRIM UP

Trim output voltage up by connecting an external resistor between Pins 8 and 9. Use the following equation, reference Table 1 for variables A and B.

$$\text{Radj-up} = \frac{A}{\Delta \%} - B \text{ (k}\Omega\text{)}$$

Example:

Trim 5% up for 12V Output units,
where $A = 1.58$, $B = 15$, $\Delta \% = 0.05$

$$\text{Radj-up} = \frac{1.58}{0.05} - 15 = 16.6 \text{ k}\Omega$$

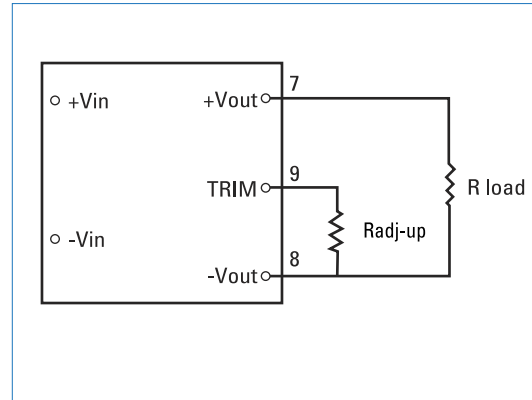

Table 1.

Output Voltage	A	B
3.3V	1.25	11
5V	1.00	9.1
12V	1.58	15
15V	1.67	15

TRIM DOWN

Trim output voltage down by connecting an external resistor between Pins 7 and 9. Use the following equation, reference Table 2 for variables C and D.

$$\text{Radj-down} = \frac{C}{\Delta \%} - D \text{ (k}\Omega\text{)}$$

Example:

Trim 5% down for 15V Output units,
where $C = 8.33$, $D = 25$, $\Delta \% = 0.05$

$$\text{Radj-down} = \frac{8.33}{0.05} - 25 = 141.6 \text{ k}\Omega$$

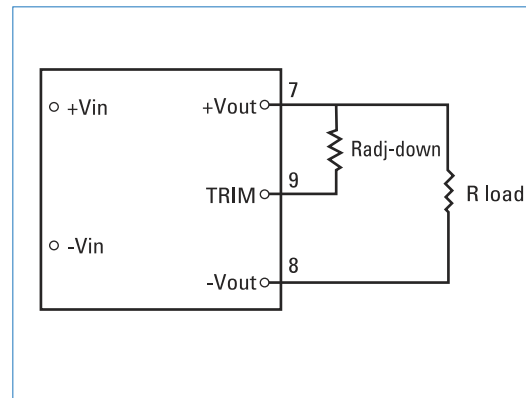

Table 2.

Output Voltage	C	D
3.3V	2.07	14.3
5V	1.00	11.1
12V	6.09	22.6
15V	8.33	25